

PROGRESSIVE CAVITY PUMPS

'SAC' INDUSTRIAL & CHEMICAL SERIES

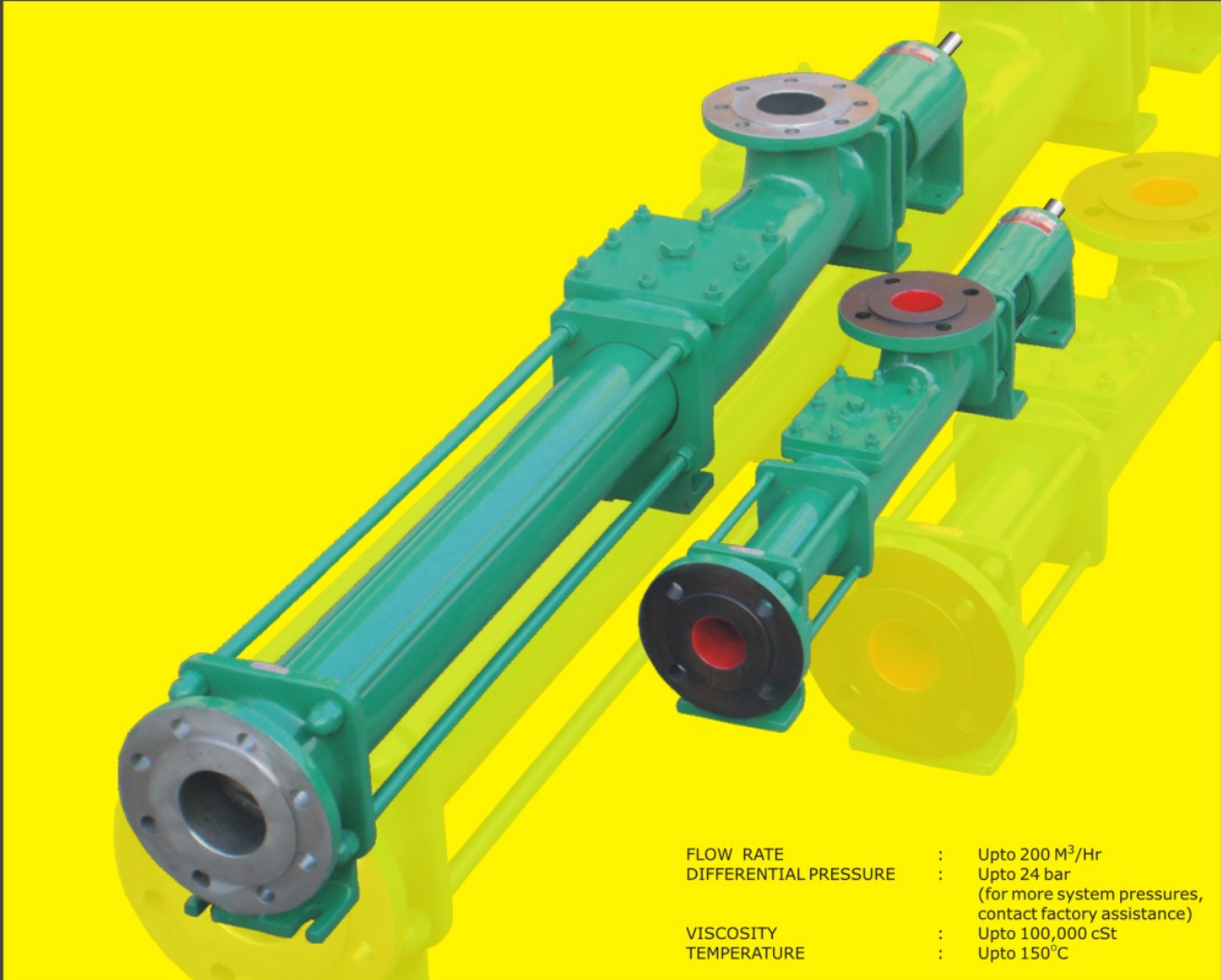

FLOW RATE	:	Upto 200 M ³ /Hr
DIFFERENTIAL PRESSURE	:	Upto 24 bar (for more system pressures, contact factory assistance)
VISCOSITY	:	Upto 100,000 cSt
TEMPERATURE	:	Upto 150°C

INDUSTRIES

Sewage • Effluent & Water
 Sugar, Distillery & Brewery
 Paper, Pulp & Cellulose
 Ceramics & Refractories
 Bulk Explosives & Emulsions
 Chemicals • Construction
 Canning • Cosmetic & Toiletries
 Edible Oil • Engineering
 Fertilizer • Marine
 Mining
 Man made Fibre
 Oil & Gas
 Paint & Varnish • Printing Ink
 Palm Oil • Soap & Detergent
 Ship Building Industries
 Starch Factories
 Cattle Feed
 Abattoir & Meat Processing
 Dye Stuff & Intermediates

FLUIDS HANDLED

Digested Sewage Sludge
 De-Watered Effluent Sludge
 Industrial Effluents • Fuel Oil Sludge
 Poly Electrolytes • Flocculants
 Molasses • Magma • Massecuite
 Spent Wash • Sulphited Sugar Syrup
 Paper Pulp upto 20% consistency
 Alum • Latex • Coating Slurry • Ferrite Slurry
 Glue • Sodium Silicate • Black Liquor
 Ceramic & Clay Slurry • Casein Slurry
 Maize Slurry • Soap Stock • Lime Slurry
 Ammonium Nitrate Solution • Resins
 Edible Oil • Gum Sludge • Cake Mix
 Acrylic Emulsion • Aluminium Hydroxide Gel
 Bentonite Slurry • Chemical Slurry
 Detergent Slurry • Epoxy Mix • Grout Mix
 Electroplating Solutions • Yeast • Instant Tea
 Lube Oil • Petroleum Jelly • Rice Bran Oil
 Tribasic Lead Sulphate • Varnish • Viscose

MATERIAL OPTIONS

HOUSING PARTS

Cast Iron, Cast Steel, CF8, CF8M, CF8ML,
 Alloy20, Hastelloy.

ROTOR & SHAFT

Ni-Cr, Nitrided Steel, Tool Steel, AISI410,
 AISI304, AISI316, Hardened & Hard
 Chrome Plated.

STATOR

NR, IIR, NBR, HNBR, EPDM, CR, CSM, Q,
 CFM, FKM in black, white, food grade,
 abrasion resistant & high temperature
 resistant variants.

SHAFT SEALING

A wide variety of gland packed &
 mechanical seal options with API plan.

PRINCIPLE

The main components which characterise the pump are a metallic single helical rotary part ROTOR and fixed double helical resilient polymer part STATOR in which the rotor turns and thereby a complex progressive sealing line (csp) is maintained. Whilst the rotor rotates inside the stator, the cavities formed between them progresses from suction to discharge end, gently carrying the media.

APPLICATIONS

Transfer, Filter & Meter of fixed or variable flow rates.

DISPLACEMENT OF CONVEYING SPACES at different rotor settings

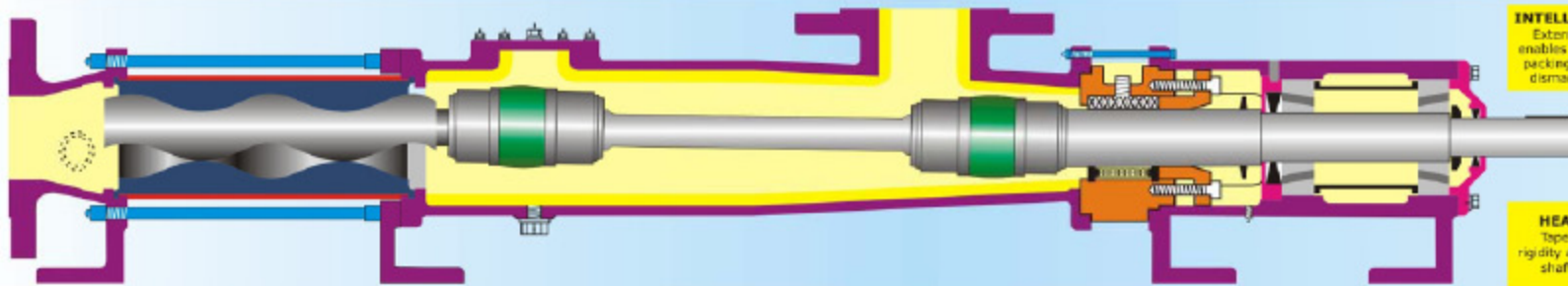

INTELLIGENT SHAFT SEALING
Externally mounted stuffing box enables easier maintenance of gland packing or mechanical seal without dismantling the bearing housing.

HEAVY DUTY BEARINGS
Taper Roller Bearings for high rigidity and concentricity of the main shaft for a longer service life.

UNIVERSAL JOINT

Cardan Joint employs two sets of perpendicular pins, each providing greater freedom of angular movement which facilitates smoother transmission of angular loads. This joint is acknowledged to be far superior than other conventional joints.

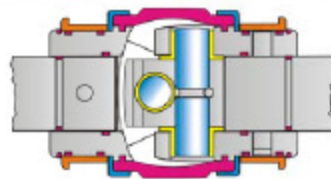

COMPLEX SEALING PROGRESSIVE LINE

The Stator forms the heart of the pump and its function depends on the complex progressive sealing line. The stators are manufactured in our state of art most modern polymer shop.

The stator cores are manufactured precisely on CNC machine centers which is achieved with the empirical and theoretical understanding of the fluid dynamics, an expertise which has been mastered over 3 decades.

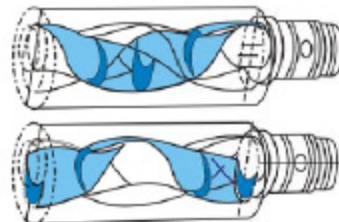

DISTINCTIVE DESIGN FEATURES

POSITIVE DISPLACEMENT

Progressing cavities deliver a uniform, metered and non-pulsating flow. The head developed is independent, and flow rate proportionate to the rotational speed.

SELF PRIMING

Can work on snore i.e., handles high percentage of air with liquid and do not require foot valves.

NON CLOGGING

Can handle solids in suspension or media containing high percentage of solids.

LOW INTERNAL VELOCITY

Minimum degradation of shear-sensitive media and can handle highly viscous pseudo-plastic materials.

LOW NPSH REQUIREMENT

Suction lift capability up to 9.5 MWC and effective even in high vacuum conditions.

REVERSIBLE

Suction and Delivery ends can be interchanged by merely changing the direction of rotation of the pump.

DRIVE ARRANGEMENTS

DIRECT DRIVE

Electric Motor, Geared Motor, Gear Box, Mechanical Speed Variator, Eddy Current DC Drive, Hydraulic, Pneumatic, Petrol & Diesel Engines.

PULLEY & V-BELT DRIVE

Overhead & 'L' Type
For accurate and variable flow rates, AC Variable Frequency Drives can be used.

OPTIONAL PROTECTION DEVICES

INTEGRAL SAFETY RELIEF VALVE

Used for plant safety whenever the possibility of the pump running against a closed valve or in-line blockade exists.

DRY RUNNING PROTECTION

Inexpensive options for dry run protection can be snore by pass, level switch or pressure switch but more reliable option is the TSE unit.

The temperature between the rotor and the stator is permanently sensed thermoelectrically via a temperature sensor integrated in the stator and compared with the limit value set at the TSE control unit.

When the pump runs dry, the temperature will rise due to the increased friction between the rotor and the stator. When the set limit value has been reached, the TSE control unit switches off the pump drive and triggers a fault message to trip the motor.

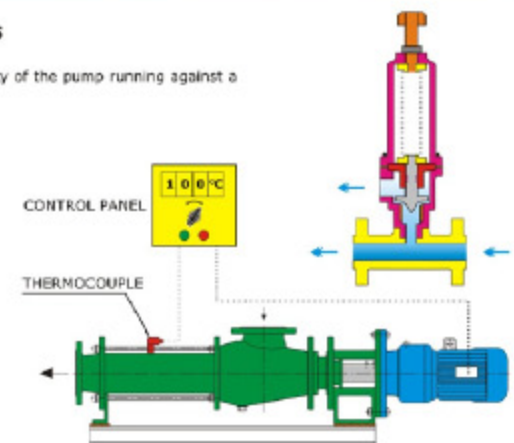

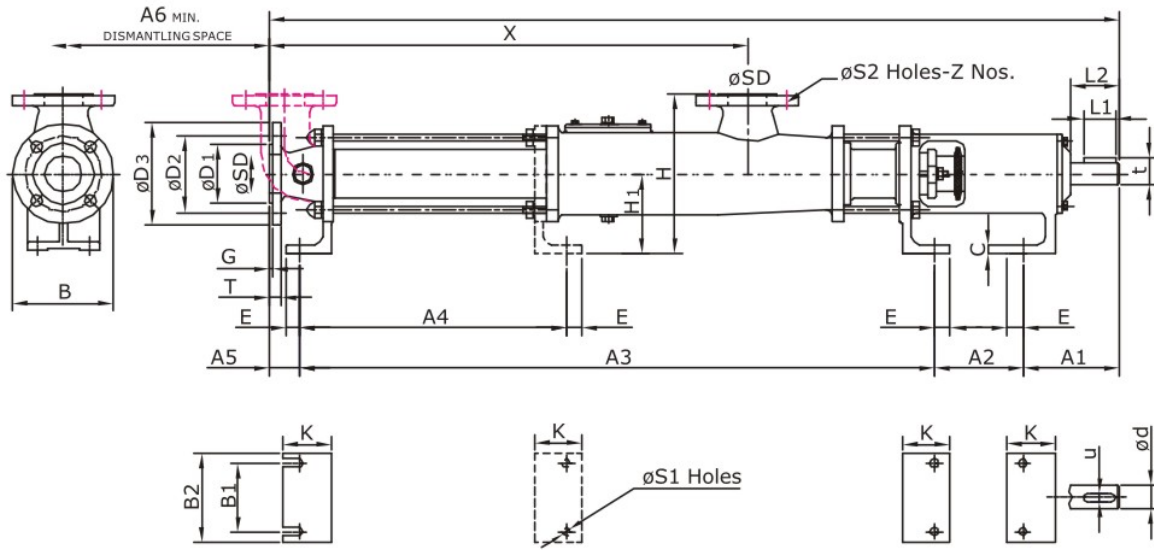

PUMP SIZE	BASIC DIMENSIONS															FLANGE DIMENSIONS					SHAFT EXTN.		Wt. Kg.								
	L	B	H	A1	A2	A3	A4	A5	A6	B1	B2	C	E	H1	K	S1	X	SD	D1	D2	D3	T		G	Z-S2	d	t	u	L1	L2	
01561	571					348										229															13
01562	649					426										307															14
02081	599	150	170	80	107	376		36	225	50	78	8	15	90	45	10	257	40	88	110	150	18	3	4-ø18	14	16	5	20	28	14	
02082	703					480										361														15	
01564	1154					830	372									685														38	
02084	1260	165	200	107	177	936	478	40	435	70	110	10	20	100	50	12	791	50	102	125	165	20	3	4-ø18	22	25	6	40	54	40	
03121	996					672										527														34	
03122	1152					828										683														44	
03124	1476					1169	699									1014														75	
04161	1065	185	244	115	150	758		42	625	78	118	12	20	112	60	12	603	65	122	145	185	20	3	4-ø18	28	31	8	40	52	58	
04162	1273					966	496									811														73	
04164	1951					1574	932									1412														111	
05201	1459	200	277	154	178	1082	440	45	825	92	134	12	25	132	70	16	920	80	138	160	200	22	3	8-ø18	32	35	10	60	77	95	
05202	1809					1432	790									1270														108	
05381	1775					1333	494									1159														160	
06241	1700					1258	419									1084														156	
06242	2012	220	320	165	228	1570	731	49	800	110	152	14	25	160	75	18	1396	100	158	180	220	24	3	8-ø18	38	40	10	60	80	177	
07281	1775					1333	494									1159														175	
07282	2185					1743	904									1569														208	
07284	2986					2464	1703									2256														240	
08321	1776					1254	493									1046														170	
08322	2182					1660	899									1452														195	
09361	1990	250	345	187	270	1468	707	65	1575	130	175	16	25	160	75	18	1260	125	188	210	250	26	3	8-ø18	48	52	14	80	100	182	
09362	2566					2044	1283									1836														222	
09881	2214					1692	931									1484														300	
09882	2994					2472	1711									2264														350	
10401	2290	290	390			1637	685	54								1343														505	
10402	2810					2157	1205									1863														560	
13521	2541			247	352	1875	923		1475	150	210	24	30	200	100	20	1594								60	66	18	100	133	625	
13522	3277	340	400			2611	1659	67								2330														700	

NOTES:-

1. ALL DIMENSIONS ARE IN m.m. AND FOR GUIDANCE ONLY, EXCEPT WHERE OTHERWISE STATED.
2. SHAFT DIAMETERS ARE TO BS 4506:1970 AND KEYWAYS TO BS 4235:1982 PART I AND ISO R773.
3. FLANGES ARE IDENTICAL AND TO BS 4504:1969. (ISO/DIN/ANSI/IS FLANGES OPTIONAL)
4. FOR FULL CERTIFIED DRAWINGS REFER TO ROTOMAC, KANPUR (INDIA)